

Schäffer

3650 T - 9660 T-2

Low style loaders:
2630 T SLT - 3650 T SLT

TELESCOPIC WHEEL LOADERS

Performance redefined



SCHÄFFER

For over 60 years, we have been developing loaders to meet individual requirements. Customer satisfaction has made us what we are today: one of the most capable and successful suppliers of farm loaders, wheel loaders and telescopic wheel loaders ever. Every day our employees create new, customised solutions. Every Schäffer loader is the result of years of experience and innovative thinking. Our products set the standard in terms of the highest possible reliability and durability. You can rely on Schäffer for lower costs throughout the whole operating life, and for performance, safety and driving comfort for many years to come.

SCHÄFFER TELESCOPIC WHEEL LOADERS: THE FUTURE OF PERFORMANCE.

When it comes to articulated telescopic loaders, Schäffer machines are the most successful in their class. Precision performance on any terrain, with lifting heights and loads that you will not find in comparable machines from our competitors. The compact design, characteristic of all Schäffer loaders, makes them easy to use particularly in

hard-to-reach areas. Add user-friendly controls found in all our models, and you have the perfect material handling solution. All loaders have the renowned Schaffer reliability whilst our design engineers have focused on rugged, modern styling to match the powerful performance of the machines.

The performance class:



2630 T SLT 18.5 kW (25 HP)



3650 T 37 kW (50 HP)
42 kW (58 HP)



3650 T SLT 37 kW (50 HP)



4670 T 48.6 kW (66 HP)



5680 T 55 kW (75 HP)



6680 T 55 kW (75 HP)



8620 T-2 75 kW (102 HP)
95 kW (129 HP)



9640 T-2 105 kW (143 HP)



9660 T-2 130 kW (177 HP)
150 kW (204 HP)

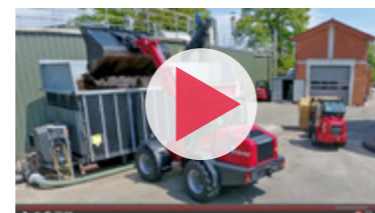

Schäffer loaders in action:
www.schaeffer.de/en/videos



**OPERATING EFFICIENCY
WITHOUT COMPROMISES**



SCHÄFFER TELE WHEEL LOADERS: THE FLEXIBLE ALL-ROUNDERS

Schäffer tele wheel loaders offer a perfect combination of performance, comfort and reliability, and are suitable for operations of all kinds. The hydrostatic traction drive delivers high thrust forces coupled with very low fuel consumption.

The machine is very simple and intuitive. The view of the attachments is excellent. The comfortable seating position guarantees relaxed and productive work at all times for the driver.

Schäffer loaders not only increase productivity, but are also genuinely fun to drive. The mode of operation and handling are very similar to that of a conventional wheel loader. And it is correspondingly easy for a driver to adjust to a Schäffer tele wheel loader. After just a short learning curve, the driver will really appreciate the additional lifting height and reach.

Especially with the larger machines from the 8620 T-2 up, it makes sense to look more closely at the different versions of the working hydraulics. The simplest variant is a gear pump whose power is already sufficient to meet many requirements. There are also heavy-duty gear pumps or flowsharing hydraulics to choose from.

Another option is load-sensing work hydraulics with high performance and excellent efficiency.

HTF: MAXIMUM THRUST, EVEN WHEN IN HIGH GEAR

HTF, or 'High Traction Force', automatically regulates the thrust so the loader can supply the highest possible thrust even in a high gear. HTF uses a new axial piston-bent axis motor that regulates speed automatically depending on the traction. This is particularly useful in an uphill position as the driver does not have to switch to first gear.

HTF comes into its own when digging into aggregate material - if more thrust is required, the hydraulic motor adapts automatically, without the driver having to interfere manually. This means most of the work can be done in fast gear, increasing driving comfort and speeding up work. All Schäffer wheel loaders with Z kinematics are equipped and delivered with the HTF-drive as standard.

Benefits:

- Very high thrust forces
- No need to manually shift down a gear when going uphill
- Even at high speed the maximum thrust is always available, e.g. when driving in muck heaps
- Enhanced driving comfort, faster working



SCHÄFFER 4670 T



4670 T: THE COMPACT TELESCOPIC WHEEL LOADER WITH HIGH STANDARDS



The 4670 T offers an ideal combination of thrust and lifting height in a compact package. The newly designed HTF drive supplies enormous traction force, drawing on the 480 bar of pressure in the drive system and improved hydraulic

efficiency. With automatic control, the full traction force is also available in high gear. The machine's maximum speed is 20 km/h, with a 30 km/h option available which can be certified for road use if specified.

When it comes to their technical details, Schäffer's compact telescopic wheel loaders more than measure up. Wear and maintenance-free Ferro-Form sliding elements in the telescopic boom, alongside the 7 t heavy-duty axles will ensure that your loader provides years of problem-free service. The articulated/pendulum joint and the oil-immersed multiple disc brake are both maintenance-free.

The 4670 T is well-powered with a 48.6 kW (66 HP) engine, so it can handle challenging tasks, and offers more agility and greater driving fun.



ELECTRONICALLY REGULATED DRIVE OFFERING MORE COMFORT



Our new Kubota motor offers the highest possible torque in its class and is unique in the market of these loaders due to an electronically regulated drive – SPT or 'Schäffer Power Transmission'. The drive is adapted to the torque of the diesel engine, for a multitude of advantages: operating costs decrease as the diesel fuel consumption is reduced. Hill starts are a lot easier as the start-up assistant helps prevent the vehicle moving backwards.

The optional potentiometer acts as a cruise control. The loader keeps a constant speed automatically and independently from the motor speed – especially convenient when working with fodder dosing devices, straw distributors, mulchers or brooms.

Additionally, there are several new safety functions, for example protection from overheating and motor over-revving protection, making working with the loader safer and more reliable. SPT is standard on the **2630 T SLT, 3650 T, 3650 T SLT, 4670 T, 5680 T and 8620 T-2** and is available as an option for the **9600** series.

Benefits:

- Higher efficiency, lower fuel consumption and reduced operating costs
- Extra safety functions including overheating and over rotation protection to make the loader safer and more reliable
- 'Start up assistant' to make hill starts easier
- Different parameters for different drive characteristics
- Optional potentiometer that works to maintain a constant speed regardless of the motor speed. This is particularly useful when working with feed dosing units, straw spreaders, mulchers or brooms (using pedal control on 8620 T-2, 9640 T-2 and 9660 T-2)
- Greater agility and more driving fun!

PURE ERGONOMICS



ERGONOMICS AT ITS BEST

Driver comfort was our top priority when designing the cabin of the 4670 T. A range of features contribute to a very comfortable work environment, so the driver can feel fresh, even after long working days. All operating and control instruments are clearly laid out and user-friendly, and easily accessed from the comfortable seat with impressive

legroom. The generous use of glass delivers perfect visibility for working and manoeuvring. The third control circuit is integrated in the joystick, with no need to change the handle to operate the additional control circuit.



Perfect view upwards with roller blind

STANDARD ON 4670 T CABIN:



Padded armrest behind joystick



Switch bar, electric plug



Multifunctional joystick



Bottle holder, battery switch

SCHÄFFER 5680 T



The new 5680 T pivot steered telescopic wheel loader offers maximum comfort for long working days. The machine has a new, larger cabin in the standard height. The enclosed cabin and quiet-running diesel engine means noise levels are low too.

The 5680 T has got a Deutz turbo engine with 55 kW (75 HP). The hydrostatic drive combines the best controllability and highest pushing power, and since all components of the drive train are perfectly matched, the fuel is converted into power sparingly and effectively. The standard hydraulic fan drive ensures quiet operation.

The maximum lifting height is 4.74 m. The 5680 T can be delivered with a protection roof instead of the cabin if requested.



The new cabin offers more space and optimised all-round visibility.



SCHÄFFER 6680 T

NEW: NOW WITH
SCV-PLUS CABIN

6680 T: **HTF**

THE NEW MEASURE

With its working weight of 5.8 t to 6.3 t, the 6680 T is the smallest loader in the professional class. The loader is driven by the latest generation 55 kW (75 HP) Deutz turbo diesel engine. It meets the requirements of the exhaust gas level stage V by using a diesel oxidation catalyst and a diesel particle filter. Because all the components in the hydrostatic drive are perfectly matched to each other, fuel consumption is converted into performance economically and effectively. The standard hydraulic fan drive reduces noise development. It is also available with an optional reverse function.

With an option for a maximum driving speed of up to 35 km/h, there are many more possibilities.

The 6680 T is equipped with an SCV-Plus cabin. With this the machine sets new standards in its class in terms of driving ergonomics, space and all-round visibility. A lower version that provides more flexibility in terms of overhead clearance is also available.



8620 T-2, 9640 T-2 AND 9660 T-2: THE NEXT GENERATION





The 86 and 96 series represent a new generation of telescopic wheel loaders from Schaffer. These loaders all meet the requirements of the exhaust gas level V - Providing an environmentally-friendly and sustainable solution.

The next generation of loaders also utilise the latest Schaffer efficiency systems - all contributing to environmentally-friendly use of the machines and to the reduction of operating costs. These technologies focus on a more efficient conversion of fuel into performance, while increasing driving comfort. HTF (see page 5) ensures maximum thrust and is standard on all new generation telescopic wheel loaders.

The electronically controlled drive SPT (page 7) comes as standard on the 8620 T-2 and is optionally available for the machines of the 96 series. The particularly economical ECO Mode (page 15), reduces the engine revs while maintaining the same speed - thus minimising fuel consumption.

Machines in the 96 series have the option of the patented 'SDCT' drive - our doubleclutch transmission that combines the advantages of a powershift transmission with those of a purely hydrostatic drive (page 16).

Availability of Schaffer efficiency systems

	8620 T-2	9640 T-2	9660 T-2
HTF 	X	X	X
SPT 	X	O	O
ECO Mode 	X	O	O
SDCT 	-	O	O

X = as standard, O = optional

Our next generation machines also have the new SCV-Plus cabin, which sets new standards in terms of comfort, all-round visibility and ergonomics. It is simply one of the best cabins in this machine class.

SCHÄFFER 8620 T-2



SCHÄFFER 8620 T-2: COUNTLESS POSSIBILITIES



The 8620 T-2 is Schaffer's telescopic wheel loader with a wealth of options so you can configure it to suit your needs. The 8620 T-2 has two options: a 75 kW/102 HP or 95 kW/129 HP Deutz engine. The standard driving speed is 20 km/h, but there is also an option with a maximum speed of 40 km/h - particularly advantageous for use outside the yard.

With an operating weight between 7 and 8 t, a lifting height at the tool pivot point of 5.20 m and a lifting capacity of 4,200 kg, the new 8620 T-2 telescopic wheel loader offers an ideal combination of features for demanding loading work. The loader is equipped with a hydraulically-driven fan as standard. Optionally, it can also be operated in reverse mode at the push of a button. The cooler is cleaned during operation - a benefit in all conditions, but particularly when working in dusty operating conditions.

The drive concept of the 8620 T-2 is also new: HTF (High Traction Force) and SPT (Schaffer Power Transmission) are standard equipment even with the smaller motor.



The 8620 T-2 is particularly efficient in ECO driving mode, standard on this machine. If conditions permit, the motor speed will reduce automatically from 2,300 revs to 1,800 revs - while maintaining the same speed. This allows a fuel saving of up to 10%. As well as reduced operating costs, benefits of ECO Mode include lower noise levels and more environmentally-friendly operation. And when higher performance is required again, the electronics automatically switch to the full rotational speed - a smart solution for efficiency and comfort.

SCHÄFFER 9640 T-2



SCHÄFFER 9640 T-2: TELESCOPIC WHEEL LOADER FOR HIGHEST DEMANDS



The impressive 9640 T-2 achieves an operating weight between 8,400 kg and 9,700 kg, depending on the ballast. With a payload of up to 4,160 kg, it lifts loads to a height of 5.40 m. The loader is powered by a powerful 105 kW / 143 HP 4-cylinder Deutz engine of the latest generation. Standard equipment includes the sensitive but extremely powerful load-sensing working hydraulics with a delivery volume of 145 l/min, the robust 24-inch tyres and hydraulically driven fan, which can also be used in reverse operation for easy cleaning.



Like the 9660 T-2, the 9640 T-2 has the option of 'SDCT' including ECO mode. 'SDCT' stands for Schaffer Dual Clutch Transmission. Two driving modes are available which can be shifted under load. In driving mode two, the loader runs at speeds of up to 40 km/h, with all the advantages

of a hydrostatic drive. In driving mode one, the loader develops enormous thrust forces thanks to a dual clutch transmission.

The patented drive allows most work to be carried out without shifting, and the transmission operates with a high degree of efficiency, so that the fuel is converted into power very economically. This is additionally supported by ECO mode, which is standard in the 40 km/h version.

With the new SCV Plus cab, the 9640 T-2 offers the best conditions for long working days. It sets high standards in driving comfort and ergonomics.

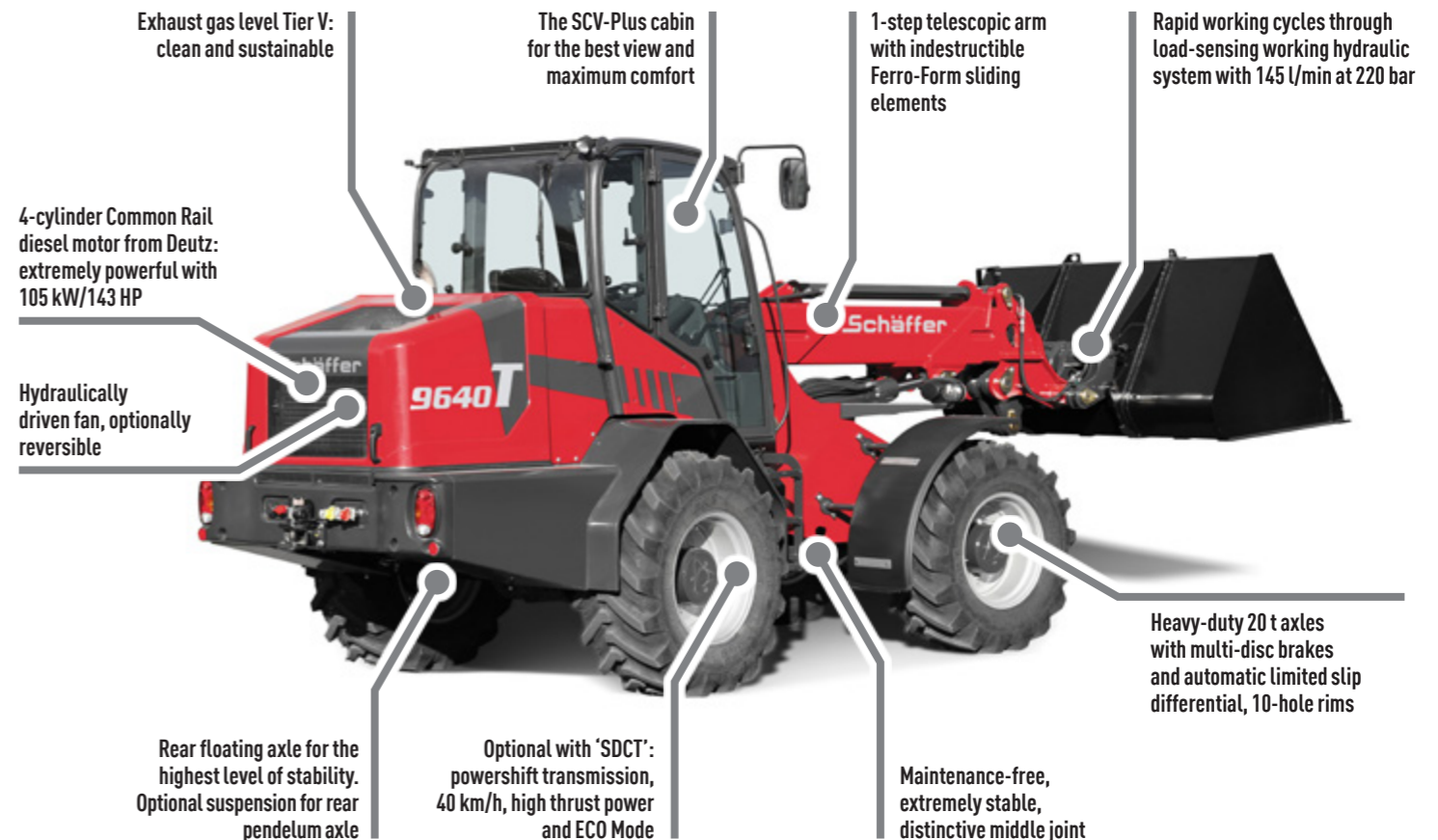

THE NEW SCV-PLUS CABIN



ERGONOMICS AND COMFORT AT THE HIGHEST LEVEL

Our 6600, 8600 and 9600 range of telescopic wheel loaders benefit from the new SCV-Plus cabin. Even at first glance, the tidy dashboard, ergonomic operating elements and the new colour co-ordinated range of switches show that this is the highest quality.

SCV stands for 'Silence, Comfort, View'. In the development of the SCV-Plus cabin, these ideas have been taken one step further. The operating elements are arranged in a more ergonomic way. The joystick is more comfortable to hold, additional functions speed up how you work. The extensive glass area offers the very best all-round visibility.

The ignition switch, along with the control system for the air-conditioning and heating systems is housed in a new console right next to the joystick. Additional, larger air outlets and removable side panels ensure the perfect supply of fresh air. With the new SCV-Plus cabin, the driver has a completely new feeling of ergonomics and comfort – nothing to stand in the way of a long working day.



THE NEW SCV-PLUS CABIN IN DETAIL



New joystick with expanded functionality



New console: ignition switch, controls for the heating and optional air-conditioning system are easy to reach



Additional, larger air outlets for perfect air circulation / optimised range of switches



12 Volt socket for charging mobile devices / 3-pin device socket



Side panels can be lifted out



New information display in the B-column for the exhaust gas system

SCHÄFFER 9660 T-2



9660 T-2: THE TELESCOPIC WHEEL LOADER WITH 6.10 M LIFTING HEIGHT

Schäffer's range of telescopic wheel loaders with articulated joints is the most extensive on the market. With an operating weight up to 13 t and a lifting height of 6.10 m, the 9660 T-2 occupies an exclusive position. The 9660 T-2 is specially developed for the requirements of biogas plants and large scale farms and combines the good all round view and traction force of a standard wheel loader with the lifting height and reach of a conventional telescopic loader.

The 9660 T-2 has an operating weight of up to 13 t, the lifting capacity is approx. 5.3 t, making it our largest and most powerful machine. The single-stage telescopic arm is robust enough to withstand even the toughest operating

conditions. Ferro-Form sliding elements, as with all Schäffer telescopic wheel loaders, promise a trouble-free telescoping process for many years to come.

The standard load sensing hydraulics provide up to 230 l/min and run very quickly even at low engine speeds. The 4-cylinder Deutz Common Rail turbo diesel engine with 130 kW (177 HP) or 150 kW (204 HP) works very efficiently as well. With a thrust of over 9,000 daN, the hydrostatic drive delivers the power needed even for the most demanding tasks.



The articulation joint is very strong and maintenance free. Two steering cylinders give perfect control.

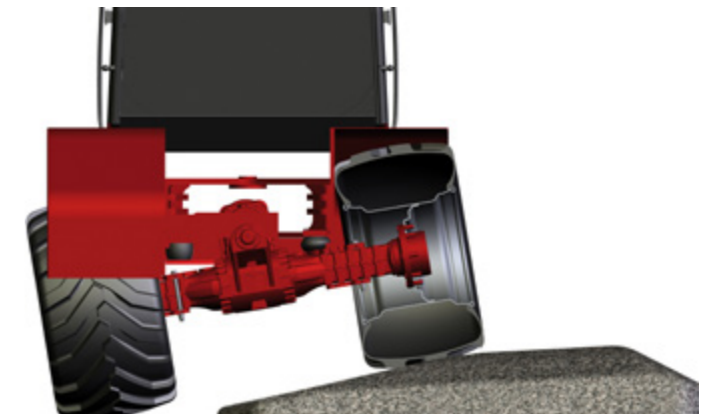

The rear axle is oscillating for best stability. The optional suspension gives safer and more comfortable operation.

9660 T-2: ADVANTAGES AT A GLANCE



High Traction Force

- Very high thrust forces
 - No need to manually shift down a gear when going uphill
 - Even at high speed the maximum thrust is always available, e.g. when driving in muck heaps
 - Enhanced driving comfort, faster working
- HTF is standard equipment of all Schaffer telescopic wheel loaders.



Schaffer Power Transmission

- Higher efficiency, lower fuel consumption and reduced operating costs
 - Extra safety functions including overheating and over rotation protection to make the loader safer and more reliable
 - 'Start up assistant' to make hill starts easier
 - Different parameters for different drive characteristics
 - Optional potentiometer that works to maintain a constant speed regardless of the motor speed. This is particularly useful when working with feed dosing units, straw spreaders, mulchers or brooms (using pedal control on 8620 T-2, 9640 T-2 and 9660 T-2)
 - Greater agility and more driving fun!
- SPT is standard on the 2630 T SLT, 3650 T, 3650 T SLT, 4670 T, 5680 T and 8620 T-2 and is optionally available for the 96 series.



Schaffer Dual Clutch Transmission

- Huge level of thrust makes it easy to fill and move a mobile silo
 - Most jobs can be carried out in a single operation, taking the strain off the clutch and the gearbox and thereby extending their service life
 - Top speed of 40 km/h, the best conditions even for usage in different areas of your business
 - Fuel economy through increased machine efficiency, reduction in operating costs
- SDCT is an available option for the telescopic wheel loaders of the 9600 series.



ECO Mode

- Fuel saving, reduction in operating costs
 - Lower noise level
 - Environmentally-friendly operation
 - No restrictions on performance
- ECO Mode is standard on the 3650 T, 3650 T SLT, 4670 T, 5680 T and 8620 T-2 and is optionally available for the 96 series.

TECHNICAL DATA

All technical specifications in this brochure refer to serial models and describe their standard functions. The equipment components and their functions as well as the accessories depend on the individual model and the product options and also on the country and customer specific requirements (the maximum values for tipping loads and payloads can only be reached with additional ballasting). Images may contain products or equipment components which are not mentioned or cannot be obtained as a standard. The descriptions, measurements, images, weight specifications and technical data correspond to the state of the art at the time of printing and are non-binding. We reserve changes in the field of construction, equipment, optics and technology without prior notice, due to the continuous development of the products. In case of doubts concerning the performance or the mode of operation of our products due to special circumstances, we recommend the execution of work samples under controlled conditions. We cannot exclude deviations from images or measurements, calculation errors, printing errors or incompleteness in the prospectus despite all due care. We do therefore not accept any liability for the correctness and completeness of the specifications in this prospectus. We do guarantee the proper functioning of our products within the scope of our General Terms and Conditions. Any guarantees that go beyond these are on principle not provided. Any liability beyond the ones set out in our General Terms and Conditions is excluded.

	2630 T SLT	3650 T	3650 T SLT	4670 T	5680 T
Engine	3-cyl. diesel engine Kubota D1703-M-Di, 18.5 kW (25 HP)	3-cyl. diesel engine Kubota D1803-CR-T (I), 37 / 42 kW (50 / 58 HP)	3-cyl. diesel engine Kubota D1803-CR-T, 37 kW (50 HP)	4-cyl. diesel engine Kubota V2403-CR-T, 48,6 kW (66 HP)	4-cyl. diesel engine Deutz TD 2.9, 55 kW (75 HP)
Exhaust gas treatment / emission level	- / V	DOC, DPF / V			
Traction hydraulics	hydrostatic-automotive, HTF				
Tyres	31x15.5-15 AS	15.0/55-17 AS Option I: 425/55-17 Option II: 440/50-17	15.0/55-17 AS Option I: 425/55-17 Option II: 440/50-17	15.0/55-17 AS Option: 425/55-17	15.5/60-18 AT-621 Option I: 12.5/80-18 Option II: 425/55-17
Service braking system	Combined brake hydrostatic and multi-disc brake				
Parking brake	Multi-disc brake running in oil bath				
Working hydraulics Output/pressure	Delivery rate: 38 l/min Operating pressure: 200 bar	Delivery rate: from 51 l/min Operating pressure: 200 bar	Delivery rate: 51 l/min Operating pressure: 200 bar	Delivery rate: from 60 l/min Operating pressure: 200 bar	Delivery rate: from 64 l/min Operating pressure: 220 bar
Steering	Fully hydraulic articulated pendulum steering				Fully hydraulic articulated steering
Lifting capacity	1,600 kg	1,950 kg	1,950 kg	2,400 kg	2,400 kg
Tipping load, straight ¹	1,330 kg	1,710 kg	1,710 kg	2,110 kg	2,660 kg
Axles	Original Schäffer axles, 6-hole rim; Option: automatic slip-control differential	Original Schäffer axles, 6-hole rim; Option: automatic slip-control differential	Original Schäffer axles, 6-hole rim; Option: automatic slip-control differential	Original Schäffer axles, 6-hole rim; planetary final drive and automatic slip-control differential	HD axles, 8-hole rim; planetary final drive and automatic slip-control differential, swing axle at rear
Operating weight	Protective roof: 2,750 kg Cabin: 2,815 kg	Protective roof: 3,600 kg Cabin: 3,800 kg	Protective roof: 3,700 kg	Protective roof: 3,900 kg Cabin: 4,000 kg	Protective roof: 4,640 kg Cabin: 4,840 kg
Speed	20 km/h in 2 gears switchable under load	20 km/h in 2 gears switchable under load, Option: 30 km/h	20 km/h in 2 gears switchable under load, Option: 30 km/h	20 km/h in 2 gears switchable under load, Option: 30 km/h	20 km/h in 2 gears switchable under load, Option: 30 km/h
Electric system	Operating voltage: 12 V				
Fill quantities	Fuel: 40 l Hydraulic oil: 30 l	Fuel: 55 l Hydraulic oil: 48 l	Fuel: 55 l Hydraulic oil: 48 l	Fuel: 55 l Hydraulic oil: 50 l	Fuel: 82 l Hydraulic oil: 81 l
Sound pressure level LpA	82 dB(A)	84 dB(A)	84 dB(A)	85 dB(A)	81 dB(A)
Sound power level guaranteed LwA equivalent LwA	101 db(A) 101 db(A)	101 db(A) 101 db(A)	101 db(A) 101 db(A)	101 db(A) 100 db(A)	101 db(A) 101 db(A)
Hand/arm vibration ²	< 2,5 m/s ²				
Total body vibration ²	< 0,5 m/s ²				

Tyre dimensions and additional equipment can change the operating weight, tipping load and payload.

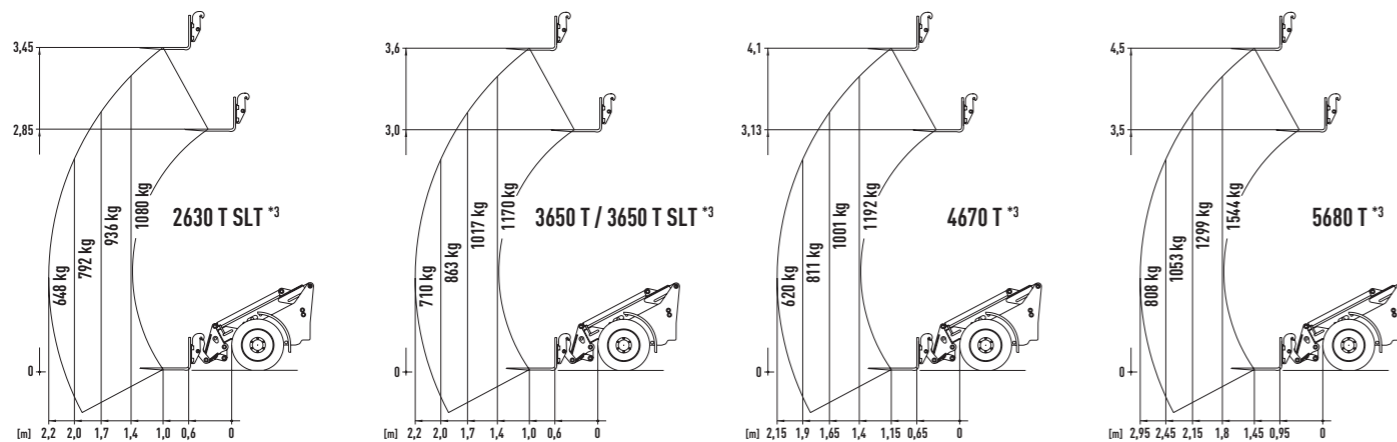

¹ boom horizontal, not extended, with pallet fork (acc. to ISO 14397) ² according to ISO 8041 ³ using forklifts on stable underground (according to EN 474-3)

	6680 T	8620 T-2	9640 T-2	9660 T-2
Engine	4-cyl. diesel engine Deutz TCD 2.9, 55 kW (75 HP)	4-cyl. diesel engine Deutz TCD 3.6, 75 / 95 kW (102 / 129 HP)	4-cyl. diesel engine Deutz TCD 3.6, 105 kW (143 HP)	4-cyl. diesel engine Deutz TCD 5.2, 130 / 150 kW (177 / 204 HP)
Exhaust gas treatment / emission level	DOC, DPF / V	DOC, DPF, SCR / V		
Traction hydraulics	hydrostatic-automotive, HTF			
Tyres	400/70-20 AS Option I: 12.5/80-18 Option II: 550/45-22.5	18-22.5 MP590 Option I: 400/70-20 AS Option II: 500/60-22.5 AS Option III: 600/40-22.5 AS	460/70R24 AS Option I: 500/70-24 Option II: 600/50-26.5 Option III: 700/40-26.5	500/70R24 AS Option I: 600/55-26.5 Option II: 700/50-26.5 Option III: 650/55-26.5
Service braking system	Combined brake hydrostatic and multi-disc brake			
Parking brake	Multi-disc brake running in oil bath			
Working hydraulics Output/pressure	Delivery rate.: from 76 l/min Operating pressure: 220 bar	Delivery rate.: from 106 l/min Operating pressure: 220 bar	Delivery rate.: 145 l/min Operating pressure: 220 bar	Delivery rate.: from 196 l/min Operating pressure: 220 bar
Steering	Fully hydraulic articulated steering			
Lifting capacity	3,100 kg	4,200 kg	4,200 kg	5,300 kg
Tipping load, straight ¹	3,820 kg	5,480 kg	5,940 kg	7,700 kg
Axles	HD axles, 8-hole rim; planetary final drive and automatic slip-control differential, swing axle at rear	Dana HD axles, 8-hole rim; planetary final drive and automatic slip-control differential, swing axle at rear	ZF HD axles, 10-hole rim; planetary final drive and automatic slip-control differential, swing axle at rear	Dana axles, 10-hole rim; planetary final drive and automatic slip-control differential, swing axle at rear
Operating weight	Cabin: 5,800 kg - 6,300 kg	Cabin: 7,050 kg - 7,950 kg	Cabin: 8,400 kg - 9,700 kg	Cabin: 12,000 kg - 13,000 kg
Speed	20 km/h in 2 gears switchable under load, Option: 35 km/h	20 km/h in 2 gears switchable under load, Option: 40 km/h	20 km/h in 2 gears switchable under load, Option: 40 km/h	30 km/h (20 km/h) in 2 gears switchable under load, Option: 40 km/h
Electric system	Operating voltage: 12 V			
Fill quantities	Fuel: 130 l Hydraulic oil: 120 l	Fuel: 150 l Hydraulic oil: 130 l	Fuel: 150 l Hydraulic oil: 130 l	Fuel: 185 l Hydraulic oil: 170 l
Sound pressure level LpA	70 dB(A)	71 dB(A)	71 dB(A)	78 dB(A)
Sound power level guaranteed LwA equivalent LwA	101 db(A) 101 db(A)	102 db(A) 101 db(A)	102 db(A) 102 db(A)	103 db(A) 101 db(A)
Hand/arm vibration ²	< 2,5 m/s ²			
Total body vibration ²	< 0,5 m/s ²			

Tyre dimensions and additional equipment can change the operating weight, tipping load and payload.

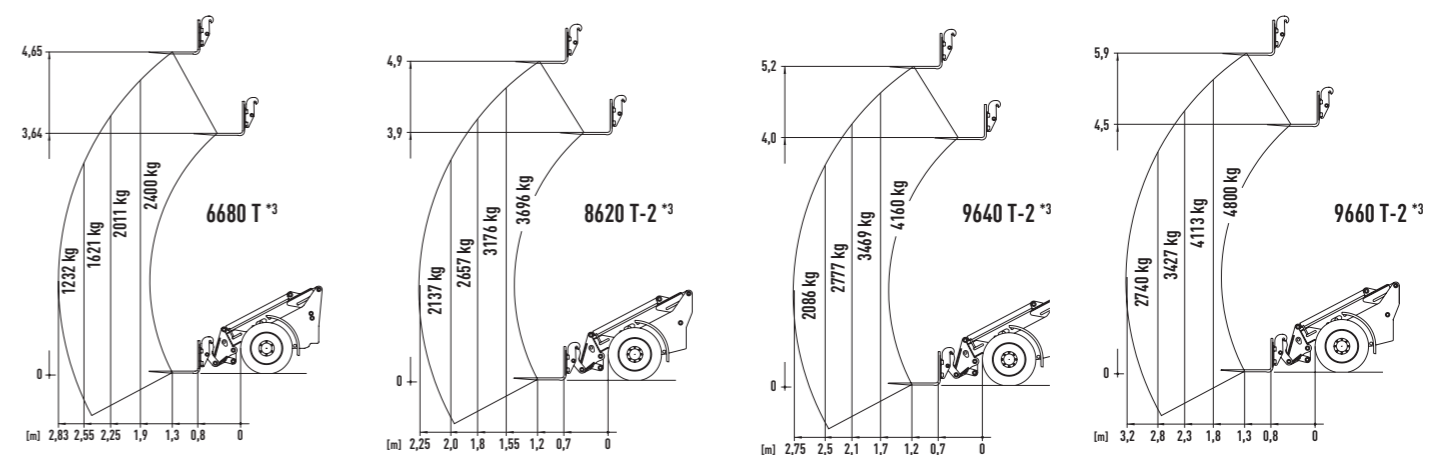

¹ boom horizontal, not extended, with pallet fork (acc. to ISO 14397) ² according to ISO 8041 ³ using forklifts on stable underground (according to EN 474-3)

DIMENSIONS

All technical specifications in this brochure refer to serial models and describe their standard functions. The equipment components and their functions as well as the accessories depend on the individual model and the product options and also on the country and customer specific requirements (the maximum values for tipping loads and payloads can only be reached with additional ballasting). Images may contain products or equipment components which are not mentioned or cannot be obtained as a standard. The descriptions, measurements, images, weight specifications and technical data correspond to the state of the art at the time of printing and are non-binding. We reserve changes in the field of construction, equipment, optics and technology without prior notice, due to the continuous development of the products. In case of doubts concerning the performance or the mode of operation of our products due to special circumstances, we recommend the execution of work samples under controlled conditions. We cannot exclude deviations from images or measurements, calculation errors, printing errors or incompleteness in the prospectus despite all due care. We do therefore not accept any liability for the correctness and completeness of the specifications in this prospectus. We do guarantee the proper functioning of our products within the scope of our General Terms and Conditions. Any guarantees that go beyond these are on principle not provided. Any liability beyond the ones set out in our General Terms and Conditions is excluded.

		2630 T SLT	3650 T	3650 T SLT	4670 T	5680 T
A	Wheelbase [mm]	1,900	1,920	1,920	2,000	2,120
B	Chassis length [mm]	3,850	4,070	4,070	4,200	4,691
C	Overall length with standard bucket [mm]	4,600	4,735	4,735	4,930	5,432
D	Digging depth [mm]	90	150	150	250	180
E	Reach [mm]	1,570	1,980	1,980	2,150	2,480
F	Max. bucket pivot point. [mm]	3,720	3,850	3,850	4,300	4,740
G	Loading height with pallet forks [mm]	3,470	3,580	3,580	4,080	4,499
H	Max. dumping height [mm]	3,010	3,010	3,010	3,480	3,862
I	Front end height [mm]	1,580	1,600	1,600	1,620	1,730
J	Dumping width [mm]	820	890	890	1,010	963
K	Seat height [mm]	955	1,180	1,080	1,300	1,330
L	Cab height [mm] Protective roof height [mm]	1,980 1,980	2,210 2,290	- 2,100	2,270 2,270	2,530 / 2,410 ** 2,410
M	Swivelling point, telescopic arm retracted [mm]	3,100	3,180	3,180	3,400	3,750
N	Overall width [mm]	1,410 - 1,590	1,420 - 1,730	1,420 - 1,730	1,420 - 1,730	1,720 - 1,820
O	Inner turning radius [mm]	1,240	1,290	1,290	1,425	1,740
P	Outer turning radius [mm]	2,740	2,710	2,710	2,845	3,460
Q	Outer radius with standard bucket [mm]	3,040	3,060	3,060	3,425	3,980

		6680 T	8620 T-2	9640 T-2	9660 T-2
A	Wheelbase [mm]	2,450	2,535	2,615	2,900
B	Chassis length [mm]	5,050	5,114	5,452	5,900
C	Overall length with standard bucket [mm]	5,780	6,031	6,260	6,950
D	Digging depth [mm]	50	75	70	80
E	Reach [mm]	2,360	2,660	2,860	3,300
F	Max. bucket pivot point. [mm]	4,950	5,200	5,400	6,100
G	Loading height with pallet forks [mm]	4,700	4,960	5,178	5,900
H	Max. dumping height [mm]	3,980	4,350	4,574	5,100
I	Front end height [mm]	1,750	1,910	1,960	2,190
J	Dumping width [mm]	815	650	740	850
K	Seat height [mm]	1,470	1,660	1,650	1,880
L	Cab height [mm] Protective roof height [mm]	2,630 / 2,530 ** -	2,770 / 2,670 ** -	2,830 / 2,730 ** -	2,900 -
M	Swivelling point, telescopic arm retracted [mm]	3,950	4,085	4,100	4,800
N	Overall width [mm]	1,800 - 2,050	2,050 - 2,230	2,330 - 2,380	2,290 - 2,490
O	Inner turning radius [mm]	1,960	2,310	2,220	2,910
P	Outer turning radius [mm]	3,760	4,390	4,560	5,200
Q	Outer radius with standard bucket [mm]	4,400	4,920	5,110	5,650

** Option: low cabin

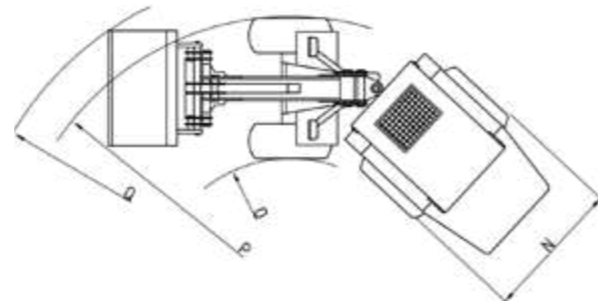
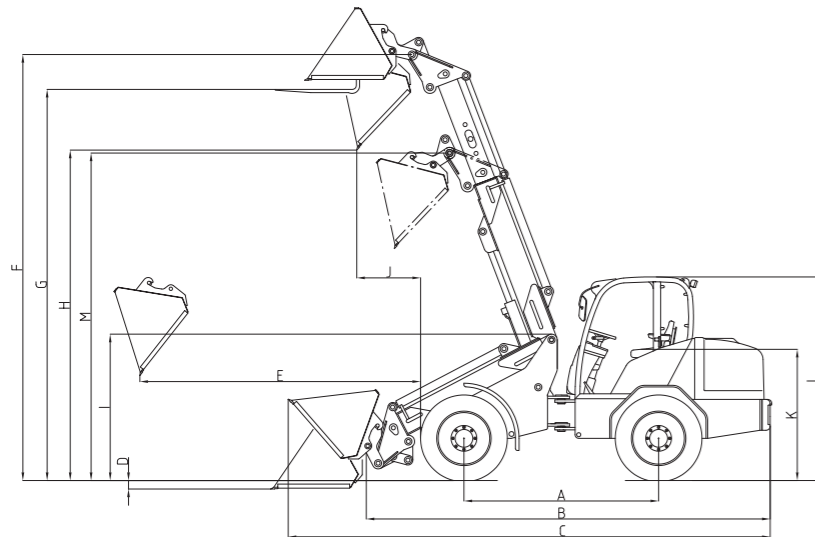

Availability of Schäffer efficiency systems

	2630 T SLT	3650 T	3650 T SLT	4670 T	5680 T	6680 T	8620 T-2	9640 T-2	9660 T-2
HTF	X	X	X	X	X	X	X	X	X
SPT	X	X	X	X	X	-	X	O	O
eco Mode	-	X	X	X	X	-	X	O	O
SDCT	-	-	-	-	-	-	-	O	O

X = as standard, O = optional



made by **SCHÄFFER**

Schäffer offers more than 30 different models, each adapted to your needs. Our loaders' range of operations is versatile: whether in agriculture or construction, gardening and landscaping, industrial and commercial applications, in stabling or warehouse management – Schäffer is always your best choice.

The way Schäffer loaders are developed, produced and serviced is unique. We bring more than 60 years' experience, and we always put the end-user first, working to make your job safer, more comfortable and more profitable. Additionally, at our Erwitte location in Germany we use state-of-the-art development and production technologies.

Ultimately, it is our employees who continuously develop new solutions, in close contact with the end user. Years of company service together with an enduring spirit form the basis for the special competence and for our global success.

The Schäffer name does not just mean unique product quality. It also stands for safety and the optimal service that we guarantee in Germany, Europe and around the globe.

Purchasing a Schäffer loader is the beginning of a long-term relationship. Your machine will only remain a 100% genuine Schäffer if you use original replacement parts. Only then will it guarantee the reliability you need, and have the right to expect. We offer you and our service partners a 24 hour delivery service – 7 days a week, 365 days a year.



YOUR DEALER:

Schäffer

Schäffer Maschinenfabrik GmbH

Auf den Thränen

D-59597 Erwitte

fon +49 (0)2943 9709-0

fax +49 (0)2943 9709-50

info@schaeffer.de



WWW.SCHAEFFER.DE/EN